



IN-CO



IN-HE



IN-SI



INPISANIN



INPINZANI

## CARACTERÍSTICAS

- Anclaje para fijación en elementos huecos como ladrillo hueco, conglomerado/cartón, tabique seco, panel de escayola, etc.
- Máxima carga en materiales base de pared delgada debido a su diseño.
- Versiones con tornillo huella Ph ranurada, cabeza hexagonal y sin tornillo.
- Colocación fácil, rápida y controlada. Requiere pistola de colocación.
- Instalación previa o a través del material a fijar.
- Disponible pinza para instalación en lugares de difícil acceso.
- Después de la instalación el tornillo puede ser sustituido por otro de la misma métrica

## MATERIALES BASE











## APLICACIONES



Ejemplos: Fijación de cuadros, apliques, evaporadores de aire acondicionado, televisiones, etc.

## 1. GAMA

ITEM	CÓDIGO	FOTO	COMPONENTES	MEDIDAS [mm]	RECUBRIMIENTO
1	IN-CO		Tornillo Camisa	M4, M5 & M6	
2	IN-HE		Tornillo Camisa	M8	
3	IN-SI		Camisa	M4, M5, M6 & M8	
4	INPISANIN		Cuerpo Empuñadura	M4, M5, M6 & M8	---
5	INPINZANI		Cuerpo Empuñadura	M4, M5 & M6	---

## 2. DATOS DE INSTALACIÓN

A continuación, se detallan los datos necesarios para realizar una correcta instalación del producto. Se especifican rangos de espesor del material base. Dependiendo del valor de este se obtendrá en consecuencia un valor de espesor máximo del elemento a fijar. Ejemplo: para INCO565, con un  $h_{min} = 20$  mm, el espesor máximo a fijar será de 35 mm. Estos valores variarán en función de la longitud del tornillo utilizado para el INSIXXX. Para una correcta instalación  $h_1 > L$ .

CÓDIGO			Métrica tornillo M [mm]	Ø Broca $d_0$ [mm]	Longitud tornillo* L [mm]	Espesor del material base $h_{min}$ [mm]	Espesor máximo del elemento a fijar** $t_{fix}$ [mm]
Con tornillo huella Ph ranurada	Con tornillo cabeza hexagonal	Sin tornillo					
INCO421	---	INSI421	M4	8	30	1 ÷ 5	17 - $h_{min}$
INCO432	---	INSI432			41	3 ÷ 10	22 - $h_{min}$
INCO438	---	INSI438			47	9 ÷ 16	30 - $h_{min}$
INCO446	---	INSI446			53	15 ÷ 22	33 - $h_{min}$
INCO459	---	INSI459			67	31 ÷ 36	52 - $h_{min}$
INCO537	---	INSI537	M5	10	46	5 ÷ 14	26 - $h_{min}$
INCO552	---	INSI552			59	6 ÷ 18	42 - $h_{min}$
INCO565	---	INSI565			72	16 ÷ 33	55 - $h_{min}$
INCO580	---	INSI580			89	33 ÷ 46	61 - $h_{min}$
---	---	INSI619	M6	12	-	1 ÷ 2	2 - $h_{min}$
INCO637	---	INSI637			46	5 ÷ 13	25 - $h_{min}$
INCO652	---	INSI652			59	6 ÷ 17	38 - $h_{min}$
INCO665	---	INSI665			72	14 ÷ 32	49 - $h_{min}$
INCO680	---	INSI680			89	34 ÷ 46	78 - $h_{min}$
---	INHE837	---	M8	14	45	5 ÷ 13	25 - $h_{min}$
---	INHE855	INSI855			60	6 ÷ 18	36 - $h_{min}$
---	INHE865	INSI865			73	17 ÷ 33	47 - $h_{min}$

### PLANO

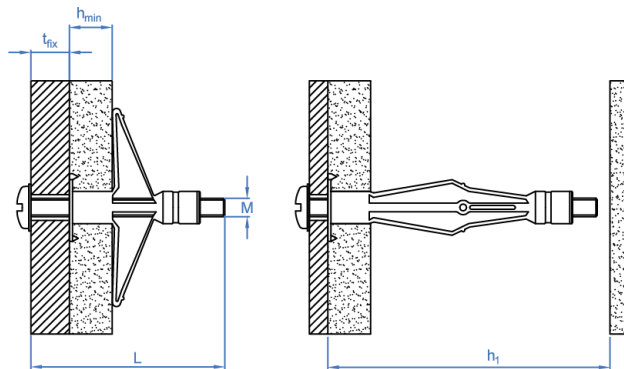

(\*) Tornillo no suministrado en la versión INSI.

(\*\*)  $t_{fix}$  en función del espesor del material base en cada caso.

## 3. INSTALACIÓN DEL PRODUCTO

### 3.1 INSTALACIÓN PREVIA

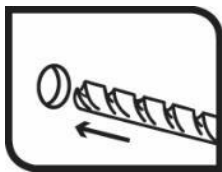

#### 1. TALADRAR

Taladrar el material base al diámetro especificado. No utilizar acción percutora.

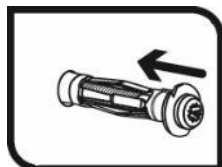

#### 2. INSTALAR

Insertar el anclaje con la mano hasta hacer tope con el material base.



Dar unos golpes suaves con el martillo hasta lograr que las estrías de la zona interna de la cabeza se claven en el material base.

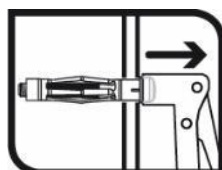

Colocar la cabeza del tornillo en la pistola de instalación. Accionar la misma hasta que se produzca la expansión total del anclaje, cuidando de no extraerlo.

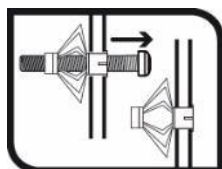

Retirar la pistola y desenroscar el tornillo.

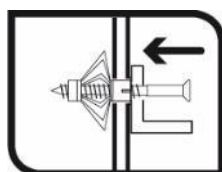

#### 3. COLOCAR EL ELEMENTO A FIJAR

Colocar el material a fijar.

Introducir el tornillo y atornillar hasta el tope.

Para el montaje en lugares de difícil acceso se recomienda el uso de la pinza (código INPINZANI) en lugar de la pistola (código INPISANIN), al tener aquella menor volumen.

En la versión anclaje sin tornillo (código INSI) la longitud mínima del tornillo a suministrar por el instalador debe ser la establecida en la tabla del apartado 2.

## 4. CARGAS MÁXIMAS RECOMENDADAS

CÓDIGO			Tabique panel yeso laminado						Tabique escayola					
			e = 10 mm		e = 12.5 mm		e = 2x12.5 mm		e = 10 mm		e = 12.5 mm		e = 2x12.5 mm	
Con tornillo huella Ph ranurada	Con tornillo cabeza hexagonal	Sin tornillo	N <sub>rec</sub>	V <sub>rec</sub>	N <sub>rec</sub>	V <sub>rec</sub>	N <sub>rec</sub>	V <sub>rec</sub>	N <sub>rec</sub>	V <sub>rec</sub>	N <sub>rec</sub>	V <sub>rec</sub>	N <sub>rec</sub>	V <sub>rec</sub>
INCO421	---	INSI421	0.20	0.50	0.20	0.50	---	---	0.20	0.50	0.30	0.60	---	---
INCO432	---	INSI432	0.20	0.50	0.20	0.50	---	---	0.20	0.50	0.30	0.60	---	---
INCO438	---	INSI438	0.20	0.50	0.20	0.50	---	---	0.20	0.50	0.30	0.60	---	---
INCO446	---	INSI446	0.20	0.50	0.20	0.50	---	---	0.20	0.50	0.30	0.60	---	---
INCO459	---	INSI459	0.20	0.50	0.20	0.50	0.30	0.90	0.20	0.50	0.30	0.60	0.50	0.80
INCO537	---	INSI537	0.20	0.50	---	---	---	---	0.25	0.50	---	---	---	---
INCO552	---	INSI552	0.20	0.50	0.20	0.50	---	---	0.30	0.60	0.50	1.00	---	---
INCO565	---	INSI565	0.20	0.50	0.20	0.50	0.40	1.00	0.30	0.50	0.50	1.00	0.90	1.10
INCO580	---	INSI580	0.20	0.50	0.20	0.50	0.40	1.00	0.30	0.50	0.50	1.00	0.90	1.10
---	---	INSI619	0.15	0.40	---	---	---	---	0.20	0.50	---	---	---	---
INCO637	---	INSI637	0.15	0.40	---	---	---	---	0.20	0.50	---	---	---	---
INCO652	---	INSI652	0.20	0.50	0.20	0.50	---	---	0.25	0.80	0.30	1.00	---	---
INCO665	---	INSI665	0.20	0.50	0.20	0.50	0.30	0.90	0.25	0.80	0.30	1.00	0.80	1.80
INCO680	---	INSI680	0.20	0.75	0.20	0.75	0.30	0.90	0.25	0.80	0.30	1.00	0.80	1.80
---	INHE837	---	0.20	0.50	0.20	0.50	---	---	0.40	0.90	0.80	1.20	---	---
---	INHE855	INSI855	0.20	0.50	0.20	0.50	---	---	0.40	0.90	0.80	1.20	---	---
---	INHE865	INSI865	0.20	0.50	0.20	0.50	0.40	1.00	0.40	0.90	0.80	1.20	0.90	1.70

Notas:

- 1KN ≈ 100 kg
- Los valores de resistencia a tracción y a cortadura deben de considerarse por separado.